

Sensors

In Brief . . .

Motorola's sensor products feature three product families of smoke ICs, acceleration, and pressure sensors. These sensors combine silicon micromachining with high volume semiconductor manufacturing technology and processes for highly accurate, reliable, repeatable, cost-effective sensors.

Acceleration Sensors

The acceleration sensor portfolio includes the PMMA1000 and PMMA2000 series sensors. This family of sensors integrates the silicon micromachined sensing element with a control chip packaged in a rugged, plastic package for maximum versatility and functionality.

Target applications: Automotive systems and industrial products

Pressure Sensors

Combining integrated circuit and micromachining technology, this diverse family of pressure sensing products offers performance, reliability and design adaptability in a single monolithic device. The versatile, cost-effective MPX series of pressure transducers are available in a number of versions:

- Fully signal conditioned for high-level output;
- High impedance, temperature compensated and calibrated, for low current designs;
- Temperature compensated and calibrated, for simplified circuits
- Uncompensated for unlimited adaptability and;
- Packaging and porting options

	Page
Introduction	5.8-2
Linearity	5.8-2
Operation	5.8-3
Typical Electrical Characteristic Curves	5.8-4
Unibody Cross-sectional Drawings	5.8-5
Pressure Side Identification	5.8-6
Selector Guide	5.8-7
Reference Table	5.8-13
Packaging Options	5.8-14

Pressure Sensors

Introduction

Motorola pressure sensors combine advanced piezoresistive sensor architecture with integrated circuit technology to offer a wide range of pressure sensing devices for automotive, biomedical, consumer and industrial applications. Selection versatility includes choice of:

Pressure Ranges in PSI

0 to 1.45, 0 to 6, 0 to 7.3, 0 to 14.5, 0 to 29, 0 to 75, 0 to 100, 0 to 150

Sensing Options

Uncompensated, Temperature Compensated/Calibrated, High Impedance, and Signal Conditioned (with on-chip amplifiers)

Application Measurements

Absolute, Differential, Gauge

Package Options

- Basic Element, Ported Elements for specific measurements
- Surface Mount, Low Profile and Top Piston fit packages

Linearity

Linearity refers to how well a transducer's output follows the equation: $V_{out} = V_{off} + \text{sensitivity} \times P$ over the operating pressure range. There are two basic methods for calculating nonlinearity: (1) end point straight line fit (see Figure 1) or (2) a least squares best line fit. While a least squares fit gives the "best case" linearity error (lower numerical value), the calculations required are burdensome.

Conversely, an end point fit will give the "worst case" error (often more desirable in error budget calculations) and the calculations are more straightforward for the user. Motorola's specified pressure sensor linearities are based on the end point straight line method measured at the midrange pressure.

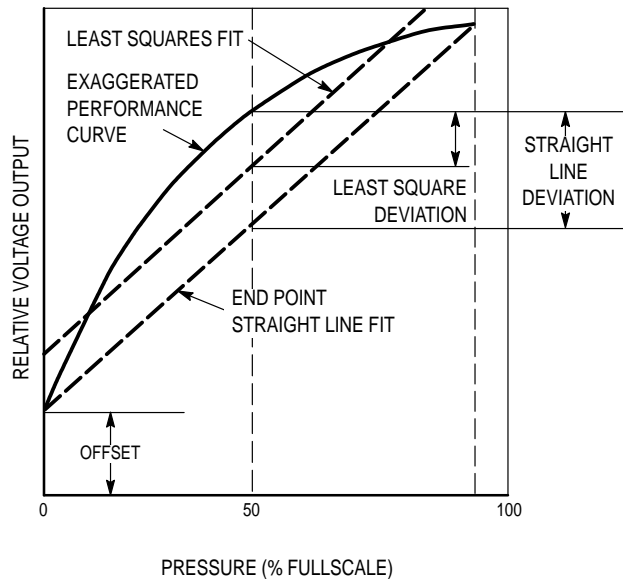

Figure 1. Linearity Specification Comparison

Operation

Motorola pressure sensors support three types of pressure measurements: Absolute Pressure, Differential Pressure and Gauge Pressure.

Absolute Pressure Sensors measure an external pressure relative to a zero-pressure reference (vacuum) sealed inside the reference chamber of the die during manufacture. This corresponds to a deflection of the diaphragm equal to approximately 14.5 psi (one atmosphere), generating a quiescent full-scale output for the MPX100A (14.5 psi) sensor, and a half-scale output for the MPX200A (29 psi) device. Measurement of external pressure is accomplished by applying a relative negative pressure to the "Pressure" side of the sensor.

Differential Pressure Sensors measure the difference between pressures applied simultaneously to opposite sides of the diaphragm. A positive pressure applied to the "Pressure" side generates the same (positive) output as an equal negative pressure applied to the "Vacuum" side.

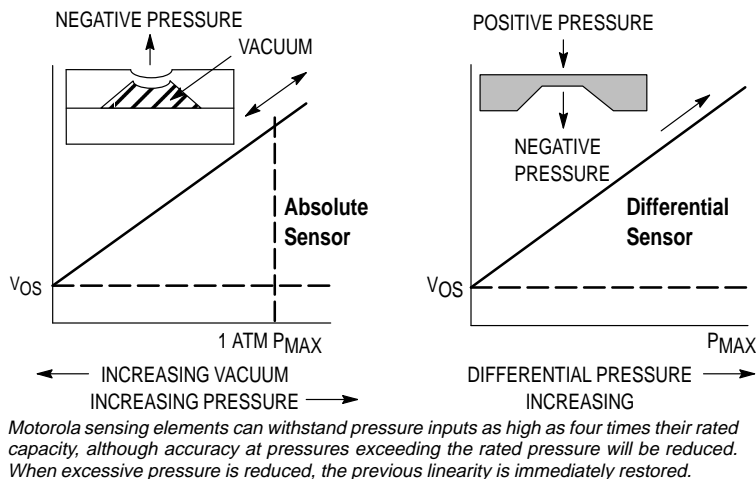

Figure 2. Pressure Measurements

Gauge Pressure readings are a special case of differential measurements in which the pressure applied to the "Pressure" side is measured against the ambient atmospheric pressure applied to the "Vacuum" side through the vent hole in the chip of the differential pressure sensor elements.

Typical Electrical Characteristic Curves

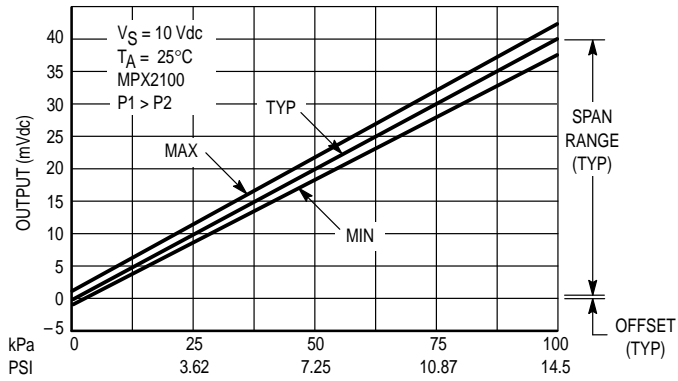

Figure 3. Output versus Pressure Differential

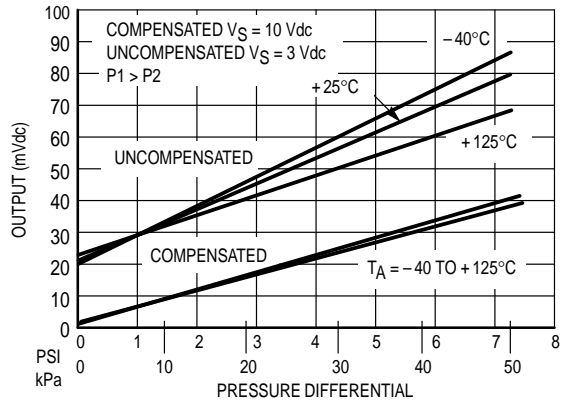

Figure 4. Typical-Output Voltage versus Pressure and Temperature for Compensated and Uncompensated Devices

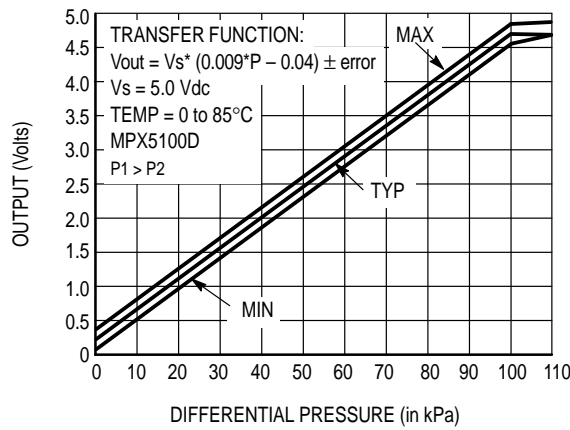

Figure 5. Signal Conditioned MPX5100

Unibody Cross-sectional Drawings

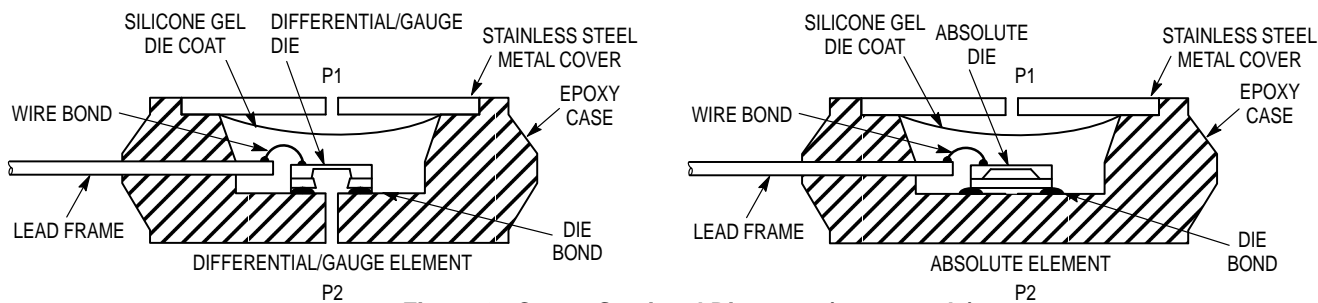

Figure 6. Cross-Sectional Diagrams (not to scale)

Figure 6 illustrates the absolute sensing configuration (right) and the differential or gauge configuration in the basic chip carrier (Case 344). A silicone gel isolates the die surface and wire bonds from harsh environments, while allowing the pressure signal to be transmitted to the silicon diaphragm.

The MPX series pressure sensor operating characteristics and internal reliability and qualification tests are based on use of dry air as the pressure media. Media other than dry air may have adverse effects on sensor performance and long term stability. Contact the factory for information regarding media compatibility in your application.

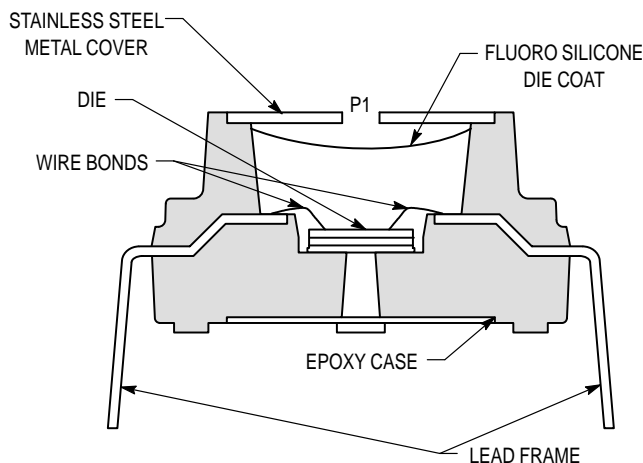

Figure 7. Cross-Sectional Diagram (not to scale)

Figure 7 illustrates the differential/gauge die in the basic chip carrier (Case 473). A silicone gel isolates the die surface and wirebonds from the environment, while

allowing the pressure signal to be transmitted to the silicon diaphragm.

Pressure Side Identification

Motorola designates the two sides of the pressure sensor as the Pressure (P1) side and the Vacuum (P2) side. The Pressure (P1) side is the side containing the silicon gel which protects the die. The differential or gauge sensor is designed to operate with positive differential pressure applied, $P1 > P2$.

The absolute sensor is designed for vacuum applied to P1 side.

The Pressure (P1) side may be identified by using the table below.

Table 1. Pressure (P1) / Vacuum (P2) Side Identification

Part Number	Case Type 4 PIN	Positive Pressure Side Identifier
MPXxxxxA MPXxxxxD	344-15	Stainless Steel Cap
MPXxxxxDP	344C-01	Side with Part Marking
MPXxxxxAP MPXxxxxGP	344B-01	Side with Port Attached
MPXxxxxGVP	344D-01	Stainless Steel Cap
MPXxxxxAS MPXxxxxGS	344E-01	Side with Port Attached
MPXxxxxGVS	344A-01	Stainless Steel Cap
MPXxxxxASX	344F-01	Side with Port Attached
Part Number	Case Type 6 PIN	Positive Pressure Side Identifier
MPXxxxxA MPXxxxxD	867-08	Stainless Steel Cap
MPXxxxxDP	867C-05	Side with Part Marking
MPXxxxxAP MPXxxxxGP	867B-04	Side with Port Attached
MPXxxxxAS MPXxxxxGS	867E-03	Side with Port Attached
MPXxxxxGVS	867A-04	Stainless Steel Cap
MPXxxxxASX	867F-03	Side with Port Attached

PRESSURE SENSOR PRODUCTS

Table 2. Uncompensated

Device Series	Max Pressure Rating		Over Pressure (kPa)	Offset mV (Typ)	Full Scale Span mV (Typ)	Sensitivity (mV/kPa)	Linearity % of FSS ⁽¹⁾ (Min) (Max)	
	psi	kPa						
MPX10D	1.45	10	75	20	35	3.5	-1.0	1.0
MPXL10	1.45	10	75	20	35	3.5	-1.0	1.0
MPX50D	7.3	50	200	20	60	1.2	-0.25	0.25
MPX100D,A	14.5	100	200	20	60	0.6	-0.25	0.25
MPX200D	29	200	400	20	60	0.3	-0.25	0.25
MPX700A*	100	700	2800	20	60	0.086	-1.0	1.0
MPX700D*	100	700	2800	20	60	0.086	-0.50	0.50

*Lifetime buy. Call factory for specific information.

Table 3. Compensated and Calibrated (On-Chip)

MPX2010D	1.45	10	75	±1.0	25	2.5	-1.0	1.0
MPXT2010D	1.45	10	75	±1.0	25	2.5	-1.0	1.0
MPX2050D	7.3	50	200	±1.0	40	0.8	-0.25	0.25
MPX2100A	14.5	100	400	±2.0	40	0.4	-1.0	1.0
MPX2100D	14.5	100	400	±1.0	40	-0.4	-0.25	0.25
MPX2200A	29	200	400	±1.0	40	0.2	-1.0	1.0
MPX2200D	29	200	400	±1.0	40	0.2	-0.25	0.25
MPX2700A	100	700	2800	±2.0	40	0.057	-1.0	1.0
MPX2700D	100	700	2800	±1.0	40	0.057	-0.5	0.5

Table 4. High Impedance (On-Chip)

MPX7050D	7.3	50	200	±1.0	40	0.8	-0.25	0.25
MPX7100A	14.5	100	400	±2.0	40	0.4	-1.0	1.0
MPX7100D	14.5	100	400	±1.0	40	0.4	-0.25	0.25
MPX7200A	29	200	400	±2.0	40	0.2	-1.0	1.0
MPX7200D	29	200	400	±1.0	40	0.2	-0.25	0.25

Table 5. Compensated and Calibrated (On-Chip) Medical Grade

Device Series	Max Pressure Rating		Supply Voltage (Vdc)	Offset mV (Max)	Sensitivity (µV/V/mmHg)	Output Impedance Ohms (Max)	Linearity % of FSS ⁽¹⁾ (Min) (Max)	
	psi	kPa						
MPX2300DT1	5.8	40	6.0	0.75	5.0	330	-2.0	2.0

⁽¹⁾Based on end point straight line fit method. Best fit straight line linearity error is approximately 1/2 of listed value.

Table 6. Signal Conditioned (On-Chip)

Device Series	Max Pressure Rating		Over Pressure (kPa)	Full Scale Span V (Typ)	Sensitivity (mV/kPa)	Accuracy (0-85 °C) % of V _{FSS}
	psi	kPa				
MPX4100A	15.2	105	400	4.59	54	±1.8
MPXS4100A	15.2	105	400	4.59	54	±1.8
MPXT4100	15.2	105	400	4.59	54	±1.8
MPX4101A	14.8	102	400	4.59	54	±1.8
MPXT4101	14.8	102	400	4.59	54	±1.8
MPX4115A	16.7	115	400	4.59	45.9	±1.5
MPXS4115A	16.7	115	400	4.59	45.9	±1.5
MPX4250A*	36.2	250	400	4.69	20	±1.5
MPXT5006D	0.87	6	1000	4.6	7.5	±3.0
MPX5010D	1.45	10	75	4.5	450	±5.0
MPXL5010D	1.45	10	75	4.5	450	±5.0
MPX5050D	7.3	50	200	4.5	90	±2.5
MPX5100D	14.5	100	400	4.5	45	±2.5
MPX5500D*	72.5	500	2000	4.5	9.0	±2.5
MPX5700D	100	700	2800	4.5	6.4	±2.5
MPX5999D	150	1000	4000	4.5	4.5	±2.5

*Lifetime buy. Call factory for specific information.

Table 7. Pressure Sensors by Pressure Range

Device Series	Maximum Pressure Rating		Device Type
	PSI	kPa	
MPX10D	1.45	10	Uncompensated
MPX2010D	1.45	10	Compensated and Calibrated (On-chip)
MPXT2010D	1.45	10	Top Piston Fit Package, Compensated and Calibrated (On-Chip)
MPX5010D	1.45	10	Signal Conditioned (On-chip)
MPXL5010D	1.45	10	Low profile package, Signal Conditioned (On-chip)
MPX2300D	5.80	40	Compensated and Calibrated Medical Grade
MPX50D	7.30	50	Uncompensated
MPX2050D	7.30	50	Compensated and Calibrated (On-chip)
MPX2052D*	7.30	50	Compensated and Calibrated (On-chip)
MPX5050D	7.30	50	Signal Conditioned (On-chip)
MPX7050D*	7.30	50	High Impedance (On-chip)
MPX100D,A	14.50	100	Uncompensated
MPX2100A,D	14.50	100	Compensated and Calibrated (On-chip)
MPX4100A	15.20	105	Signal Conditioned (On-chip)
MPXS4100A	15.20	105	Surface mount package, Signal Conditioned (On-chip)
MPX4101A	14.80	102	Signal Conditioned (On-chip)
MPX4115A	16.70	115	Signal Conditioned (On-chip)
MPXS4115A	16.70	115	Surface mount package, Signal Conditioned (On-chip)
MPX5100A,D	16.70	115	Signal Conditioned (On-chip)
MPX7100A,D	14.50	100	High Impedance (On-chip)
MPX200	29.00	200	Uncompensated
MPX2200A,D	29.00	200	Compensated and Calibrated (On-chip)
MPX7200A,D*	29.00	200	High Impedance (On-chip)
MPX4250A	36.20	250	Signal Conditioned (On-chip)
MPX5500D*	75.00	500	Signal Conditioned (On-chip)
MPX700A,D*	100.00	700	Uncompensated
MPX2700D	100.00	700	Compensated and Calibrated (On-chip)
MPX5700D	100.00	700	Signal Conditioned (On-chip)
MPX5999D	150.00	1000	Signal Conditioned (On-chip)

*Lifetime buy. Call factory for specific information.

Table 8. MPX10/50/100/200/700 Series (Uncompensated)

Device Type	Measurement/Porting Options	Package Options	Pressure Range				
			0 to 1.45 PSI (0 to 10 kPa)	0 to 7.3 PSI (0 to 50 kPa)	0 to 14.5 PSI (0 to 100 kPa)	0 to 29 PSI (0 to 200 kPa)	0 to 100 PSI (0 to 700 kPa)
4-Pin	Absolute	Case 344-15	—	—	MPX100A	—	—
Basic Elements	Differential	Case 344-15	MPX10D	MPX50D	MPX100D	MPX200D	—
Ported Elements	Absolute Port	Case 344B-01	—	—	MPX100AP	—	—
	Absolute Stovepipe	Case 344E-01	—	—	MPX100AS	—	—
	Absolute Axial	Case 344F-01	—	—	MPX100ASX	—	—
	Differential Port	Case 344C-01	MPX10DP	MPX50DP	MPX100DP	MPX200DP	—
	Gauge	Case 344B-01	MPX10GP	MPX50GP	MPX100GP	MPX200GP	—
	Gauge Stovepipe	Case 344E-01	MPX10GS	—	—	—	—

Table 9. MPX2000 Series (Temperature Compensated and Calibrated On–Chip)

Device Type	Measurement Options	Package Options	Pressure Range				
			0 to 1.45 PSI (0 to 10 kPa)	0 to 7.3 PSI (0 to 50 kPa)	0 to 14.5 PSI (0 to 100 kPa)	0 to 29 PSI (0 to 200 kPa)	0 to 100 PSI (0 to 700 kPa)
4–Pin Basic Elements	Absolute	Case 344–15	—	—	MPX2100A	MPX2200A	MPX2700A
	Differential	Case 344–15	MPX2010D	MPX2050D	MPX2100D	MPX2200D	MPX2700D
Ported Elements	Absolute Port	Case 344B–01	—	—	MPX2100AP	MPX2200AP	—
	Absolute Axial	Case 344F–01	—	—	MPX2100ASX	—	—
	Differential Port	Case 344C–01	MPX2010DP	MPX2050DP	MPX2100DP	MPX2200DP	MPX2700DP
	Gauge	Case 344B–01	MPX2010GP	MPX2050GP	MPX2100GP	MPX2200GP	—
	Gauge Vacuum	Case 344D–01	—	—	MPX2100GVP*	—	—
	Gauge Stovepipe	Case 344E–01	MPX2010GS	—	—	—	—
	Gauge Vacuum Stovepipe	Case 344A–01	—	—	—	—	—
	Gauge Axial	Case 344F–01	MPX2010GSX	MPX2050GSX	MPX2100GSX	—	—

*Lifetime buy. Call factory for specific information.

Table 10. MPX4000 Series (Signal Conditioned On–Chip)

Device Type	Measurement Options	Package Options	Pressure Range			
			3 to 15 PSI (20 to 105 kPa)	2.3 to 14.7 PSI (15 to 102 kPa)	2.3 to 16.6 PSI (15 to 115 kPa)	3 to 36.2 PSI (20 to 250 kPa)
6–Pin Basic Element	Absolute	Case 867–08	MPX4100A	MPX4101A	MPX4115A	MPX4250A
Ported Element	Absolute Port	Case 867B–04	MPX4100AP	—	MPX4115AP	MPX4250AP
	Absolute Stovepipe	Case 867E–03	MPX4100AS	—	MPX4115AS	—
	Absolute Axial	Case 867F–03	—	—	—	—
8–Pin Basic Element	Absolute	Case 471–01	MPXS4100A	—	—	—
Ported Element	Absolute Axial	Case 471B–01	—	—	MPXS4115A	—
	Absolute Side Port	Case 471A–01	—	—	—	—

Table 11. MPX5000 Series (Signal Conditioned On-Chip)

Device Type	Measurement Options	Package Options	Pressure Range						
			0 to 1.45 PSI (0 to 10 kPa)	0 to 7.3 PSI (0 to 50 kPa)	0 to 14.5 PSI (0 to 100 kPa)	2.3 to 16.6 PSI (15 to 115 kPa)	0 to 75 PSI (0 to 500 kPa)	0 to 100 PSI (0 to 700 kPa)	0 to 150 PSI (0 to 1000 kPa)
6-Pin Basic Element	Absolute	Case 867-08	—	—	—	MPX5100A	—	—	—
	Differential	Case 867-08	MPX5010D	MPX5050D	MPX5100D	—	MPX5500D*	MPX5700D	MPX5999D
Ported Element	Absolute Port	Case 867B-04	—	—	—	MPX5100AP	—	—	—
	Differential Port	Case 867C-05	MPX5010DP	MPX5050DP	MPX5100DP	—	MPX5500DP*	MPX5700DP	—
	Gauge	Case 867B-04	MPX5010GP	MPX5050GP	MPX5100GP	—	MPX5500GP*	MPX5700GP	—
	Gauge Stovepipe	Case 867E-03	MPX5010GS	—	—	—	—	—	—
	Gauge Axial	Case 867F-03	MPX5010GSX	—	—	—	—	—	—

*Lifetime buy. Call factory for specific information.

Table 12. MPX7000 Series (Temperature Compensated and Calibrated High Impedance On-Chip)

Device Type	Measurement Options	Package Options	Pressure Range		
			0 to 7.3 PSI (0 to 50 kPa)	0 to 14.5 PSI (0 to 100 kPa)	0 to 29 PSI (0 to 200 kPa)
4-Pin Basic Elements	Absolute	Case 344-15	—	MPX7100A	MPX7200A
	Differential	Case 344-15	MPX7050D	MPX7100D	MPX7200D
Ported Elements	Absolute Port	Case 344B-01	—	MPX7100AP	—
	Differential Port	Case 344C-01	MPX7050DP	MPX7100DP	—
	Gauge	Case 344B-01	MPX7050GP	MPX7100GP	MPX7200GP
	Gauge Stovepipe	Case 344E-01	MPX7050GS	MPX7100GS	—
	Gauge Axial	Case 344F-01	MPX7050GSX	—	—

Device Numbering System for Pressure Sensors

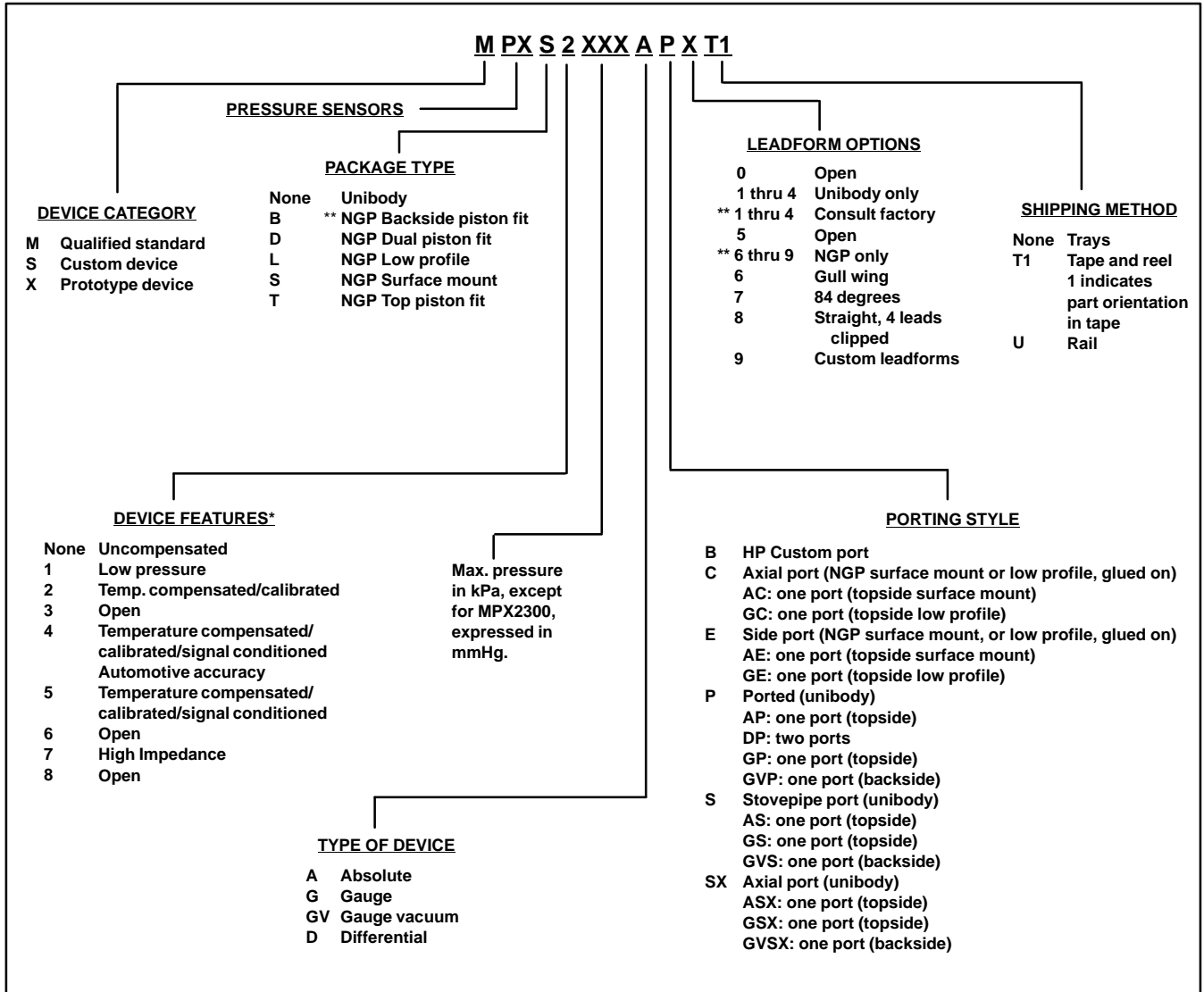

Note: Actual device marking may be abbreviated due to space constraints but packaging label will reflect full part number.

*Only applies to qualified and prototype devices. This does not apply to custom devices.

Examples: MPX100AP 100 kPa uncompensated, absolute device in unibody package with one port (topside), no leadform, shipped in trays.
 MPXS4100A6U 100 kPa automotive temp. compensated and calibrated device with signal conditioning, NGP surface mount with gull wing leadform, shipped in rails

**NGP – Next Generation Package

ACCELERATION SENSOR PRODUCTS

Table 13. Accelerometer Sensor

Device	Range	Sensitivity	Frequency/ Bandwidth (Hz)	Sensing Direction	Supply Current (mA) Nominal	Zero Acceleration Output
PMMA1000	±40g	40 mV/g	400	Z axis	5	2.5
PMMA2000	±40g	40 mV/g	400	X axis	5	2.5

Device Numbering System for Accelerometers

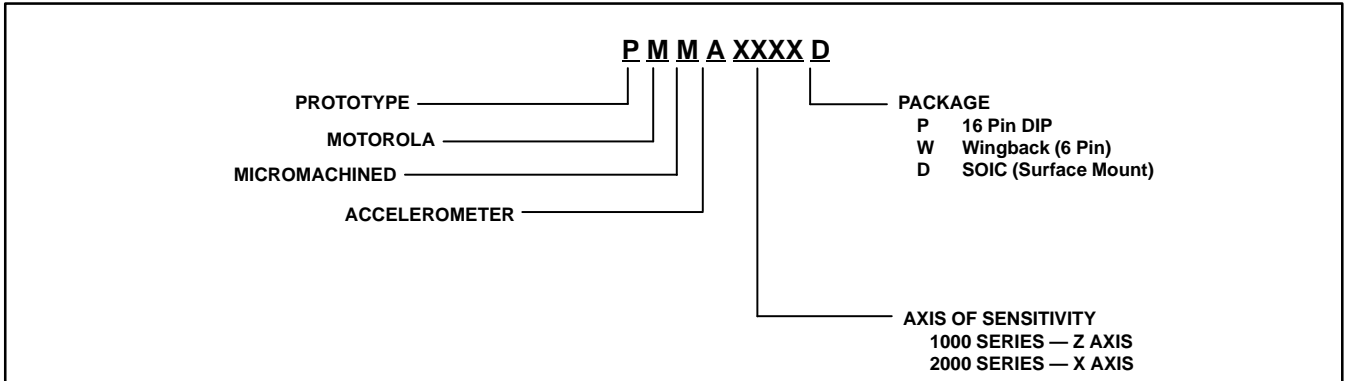

EVALUATION TOOLS

Table 14. Literature

Marketing Literature	Description
DL200/D HB218/D SG162/D	Sensor Device Data Book, Rev 3 Pressure Sensor Distributor Handbook SPD Selector Guide, Rev 24
Application Notes	Description
AN1516/D AN1551/D AN1552/D AN1556/D AN1557/D AN1559/D AN1571/D AN1573/D AN1583/D AN1584/D AN1585/D AN1586/D AN1611/D AN1612/D AN4004/D AN1620/D AN1621/D AN1622/D AN1625/D AN1640/D AN1638/D AN1632/D AN1646/D	Liquid Level Control Using a Motorola Pressure Sensor Low Pressure Sensing with the MPX2010 Pressure Sensor MPX7100AP: The Sensor at the Heart of Solid-State Altimeter Applications Designing Sensor Performance Specifications for MCS-Based Systems A Cookbook Approach to Designing a Differential-Signal Amplifier for Sensor Applications Application Considerations for a Switched Capacitor Accelerometer Digital Blood Pressure Meter Understanding Pressure and Pressure Measurement Motorola's Next Generation Piston Fit Pressure Sensor Packages "Very Low-Pressure" Smart Sensing Solution with Serial Communications Interface High-Performance, Dynamically-Compensated Smart Sensor System Designing a Homemade Digital Output for Analog Voltage Output Sensors Impact and Tilt Measurement Shock and Mute Pager Applications Using Accelerometer +2g Acceleration Sensing Module Based on a +40g Integrated Accelerometer Monolithic Integrated Solution for MAP Sensors Integrated Silicon Bulk Micromachined Barometric Pressure Sensor for Control Unit and External Mount EMC Considerations for Automotive Sensors Low Cost Digitized CO Application Board Reducing Accelerometer Susceptibility to BCI Offset Calibration of Gauge Pressure Sensors Using Parallel I/O Ports MMA1000P Product Overview and Interface Considerations Noise Considerations for Integrated Pressure Sensors

REFERENCE TABLE

Table 15. Pressure Unit Conversion Constants (Most Commonly Used — Per International Conventions)

	PSI ⁽¹⁾	in. H ₂ O ⁽²⁾	in. Hg ⁽³⁾	K Pascal	millibar	cm H ₂ O ⁽⁴⁾	mm Hg ⁽⁵⁾
PSI ⁽¹⁾	1.000	27.681	2.036	6.8948	68.948	70.309	51.715
in. H ₂ O ⁽²⁾	3.6126×10^{-2}	1.000	7.3554×10^{-2}	0.2491	2.491	2.5400	1.8683
in. Hg ⁽³⁾	0.4912	13.595	1.000	3.3864	33.864	34.532	25.400
K Pascal	0.14504	4.0147	0.2953	1.000	10.000	10.1973	7.5006
millibar	0.01450	0.40147	0.02953	0.100	1.000	1.01973	0.75006
cm H ₂ O ⁽⁴⁾	1.4223×10^{-2}	0.3937	2.8958×10^{-2}	0.09806	0.9806	1.000	0.7355
mm Hg ⁽⁵⁾	1.9337×10^{-2}	0.53525	3.9370×10^{-2}	0.13332	1.3332	1.3595	1.000

PRESSURE PACKAGING OPTIONS

4-PIN

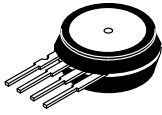

BASIC ELEMENT
CASE 344-15
SUFFIX A/D



GAUGE PORT
CASE 344B-01
SUFFIX AP/GP

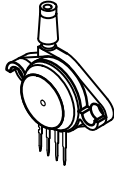

GAUGE VACUUM PORT
CASE 344D-01
SUFFIX GVP

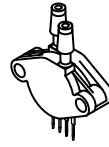

DUAL PORT
CASE 344C-01
SUFFIX DP

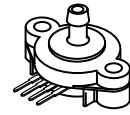

AXIAL PORT
CASE 344F-01
SUFFIX ASX/GSX

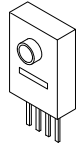

MEDICAL CHIP PACK
CASE 423-04

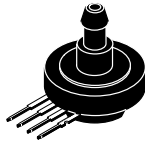

STOVEPIPE PORT
CASE 344A-01
SUFFIX GVS

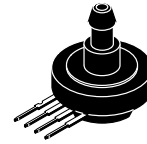

STOVEPIPE VACUUM PORT
CASE 344E-01
SUFFIX AS/GS

6-PIN

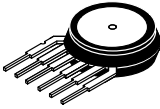

BASIC ELEMENT
CASE 867-08
SUFFIX A/D



GAUGE PORT
CASE 867B-04
SUFFIX AP/GP

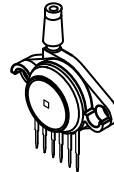

GAUGE VACUUM PORT
CASE 867D-04
SUFFIX GVP

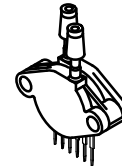

DUAL PORT
CASE 867C-05
SUFFIX DP

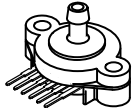

AXIAL PORT
CASE 867F-03
SUFFIX ASX/GSX



STOVEPIPE PORT
CASE 867E-03
SUFFIX AS/GS



STOVEPIPE VACUUM PORT
CASE 867A-04
SUFFIX GVS

8-PIN

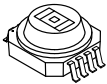

BACKSIDE PISTON FIT
CASE 474A-01



SURFACE MOUNT
CASE 471-01

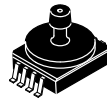

**SURFACE MOUNT
AXIAL PORT**
CASE 471B-01

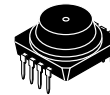

TOP PISTON FIT
CASE 473A-01

ACCELEROMETER PACKAGING

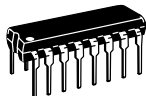

DIP PACKAGE
CASE 648C-03

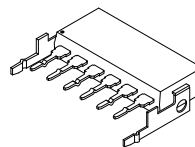

WINGBACK PACKAGE (WB)
CASE 456-03